

APPLICATION FOR PERMIT TO INSTALL A MAILBOX

To: Auglaize County Engineer
P.O. Box 59
1014 S. Blackhoof St.
Wapakoneta, OH 45895

Date: _____

Application is hereby made by: _____

Location of installation: _____

Type of work & complete location: _____

Along/Across CR# _____, _____ Township. Work will commence on or about _____, and will require _____ days.

I / We agree to the following conditions:

- 1) The support structure for the mailbox installation shall be no larger than a 4" x 4" treated wooden post or no larger than a 2" diameter steel post. Post weights are not to exceed 2.6 pounds per foot, and shall not be buried no deeper than 24" and backfilled with either native soils or gravel only (no concrete).
- 2) The base of the actual mailbox shall be installed 38" from the ground surface, and the face of the mailbox shall be installed 5 feet from the edge of the roadway pavement with gravel approaches in-place.
- 3) It is not recommended to use plastic or decorative wooden mailboxes. Frigid temperatures as well as snow and ice removal operations of highway crews will crack, fracture, or even shatter these types of mailboxes. The preferred installation would be to use an aluminum mailbox on a steel sign post. The County Engineer is not responsible for loss or damage to mailboxes caused from snow and ice removal from the roadways during the winter season, unless the mailbox was physically hit by a snowplow.
- 4) That traffic will be maintained at all times, unless permission is granted by the County to temporarily close the road. It shall be the responsibility of the applicant to contact the Auglaize County Sheriff's Office about pending work that may cause a disturbance to in-season school bus routes, safety, fire and rescue services, or ambulatory services.
- 5) That lights, signs barricades and, if necessary, flagmen and watchmen, will be placed on the job for the protection of traffic at all times, day and night, during the time this work is being done and that instructions given by the County, as to handling of traffic, will be fully complied with.
- 6) That disturbance to road surface and shoulders will be kept at a minimum and that post excavation will be backfilled with gravel and tamped, so that settlement of material will be minimized. If settlement does occur, additional suitable material will be put into place and compacted.
- 7) That the road surface at the post excavation will be replaced with material of the type that was removed (or other material suitable to the County) and that the new surface will conform to the grade of the undisturbed surface.
- 8) If, in the future, improvements or relocations are made to any of the above portions of County Roads, it will be the financial responsibility of the applicant or new owners to move or relocate such installations at the request of the County.
- 9) That I/We assume the responsibility for and will save the County harmless from any and all claims for personal injuries and property damages, and shall defend any action that might be brought due to this work.
- 10) IT IS REQUIRED THAT YOU CALL THE OHIO UTILITY PROTECTION SERVICE (OUPS) AT LEAST 48 HOURS BEFORE YOU DIG. CALL 1-800-362-2764

Applicant to notify the County Engineer before starting construction.
Phone: 419-739-6520

SIGNED: _____
ADDRESS: _____

PHONE: _____
EMAIL: _____

Permit to do this work under the conditions stated above is hereby granted.

Date: _____

NOTES:

- 1) The 911 house number is determined by the Auglaize County Engineer's Tax Map Office.
- 2) The actual sign and lettering is provided by the Township Trustees for the township in which the installation is being made.

SINGLE MAILBOX INSTALLATION

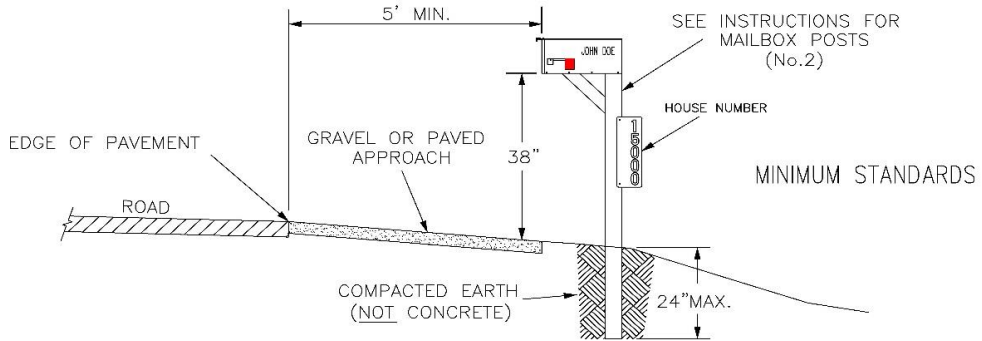

GROUP MAILBOXES
WITH ANTI-TWIST PLATES
(METAL POSTS ONLY)

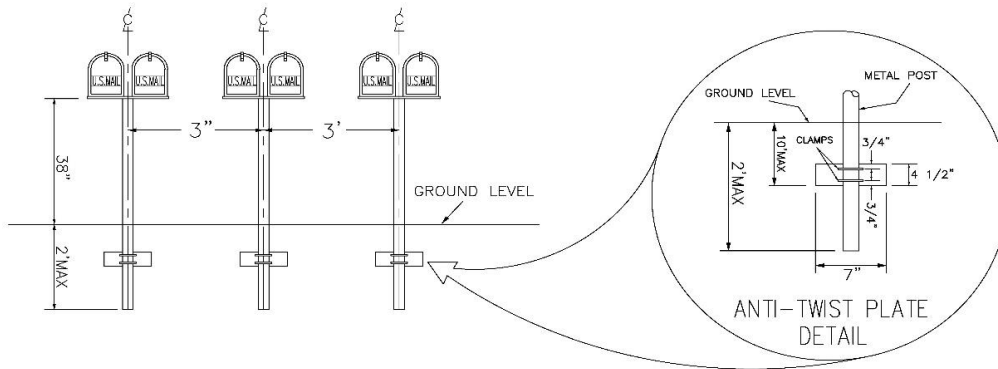

MAILBOX APPROACH

